

ECO/SUPERIOR 700

SUPERIOR 700



ECO 700



User manual



Gram Scientific ApS. (CVR No. 43122193)
Aage Grams Vej 1
6500 Vojens

Intended use	4
Safety information	5
Location	5
Optimizing the energy consumption	12
General description	13
Refrigerant / GWP value	13
Climate / temperature class	13
Electrical connection	14
General use	15
Operating the product	17
Keylock	18
Adjusting the cabinet temperature	18
Dry cooling	19
Setting temperature alarm parameters	19
Temperature alarms	20
Messages and alarms shown in the display	21
Defrosting	22
Troubleshooting	22
Defrost water	23
Light - solid door	24
Light - glass door	24
Power failure	24
Cleaning	24
Door gaskets	25
Long term storage	25
Service	25
Positioning of the name plate	26
Disposal	27
Declaration of conformity	28
Wiring diagram – Eco R/C 700 – Superior C 700	30
Wiring diagram – Eco/Superior F 700	31
Piping diagram	32

ENGLISH

Thank you for choosing a quality product from Gram Professional.

This manual will advise you how to install, use and maintain your new product.

Before our products leave the factory, they undergo a full function and quality test.

Should you nevertheless experience problems with the product, then contact your local dealer. Gram Professional representatives and dealers placed all over the world are ready to help you.

Please refer to your dealer for information about the warranty coverage of your new product.

Any warranty is subject to correct use according to specifications in this user manual, where e.g. common maintenance and eventual repairs are carried out by authorized technicians with proper knowledge of the product and only using original spare parts.

Changes in installation and other use of the product than specified in this manual, might affect the operation and durability of the product.

The manual is written according to our current technical knowledge. We constantly work on updating this information, and we reserve the right to make technical changes.

Intended use

The product is intended for the storage of foods in non-household environments but not for the display to or access by customers.

The product is designed for usage at a constant temperature and is not to be used for chilling down or freezing hot/fresh food.

The product is only to be used for the purpose for which it has been expressly designed. Any other use could cause damage to the food or even to the product.

The product is not suited for storing blood plasma, laboratory samples, pharmaceuticals or similar substances.

The manufacturer will not be held liable or responsible for any damage caused by improper, incorrect or unreasonable use of the product.

Safety information

Important

Description of symbols used in this manual.



Warning Lacking observation to these instructions might result in accidents with personal injury.



Important If these instructions are not observed, the product might be damaged or destroyed.

Be aware that Gram Professional has taken precautions to ensure that the safety of the product is in order.

Please read carefully the following information regarding safety.



It is important, that everyone using or installing the product, does have access to this manual.



This appliance is not intended for use by persons with reduced physical, sensory or mental capabilities, or lack of experience and knowledge, unless they have been given supervision or instruction concerning use of the appliance by a person responsible for their safety.



Children should not use this appliance unless they are supervised to ensure that they do not play with the appliance.



The appliance might contain parts with sharp edges in the compressor compartment, and in the inside compartment.



The appliance is not to be transported on a sack truck, there is a danger of losing the balance, causing danger to persons.



Do not pull the power cord to disconnect the appliance, or when moving the appliance.

Location

When receiving the cabinet, check the packaging material for damage.

If any damage occurs at the packaging material, it should be considered if the cabinet might have been damaged too. If the damage is substantial, please contact your dealer.

Inside the cabinet there is a cardboard box containing either four legs or four castors, including whatever is needed for the mounting. For the Superior cabinets it also contains a pedal door opener.

See the delivered parts on the illustration below.

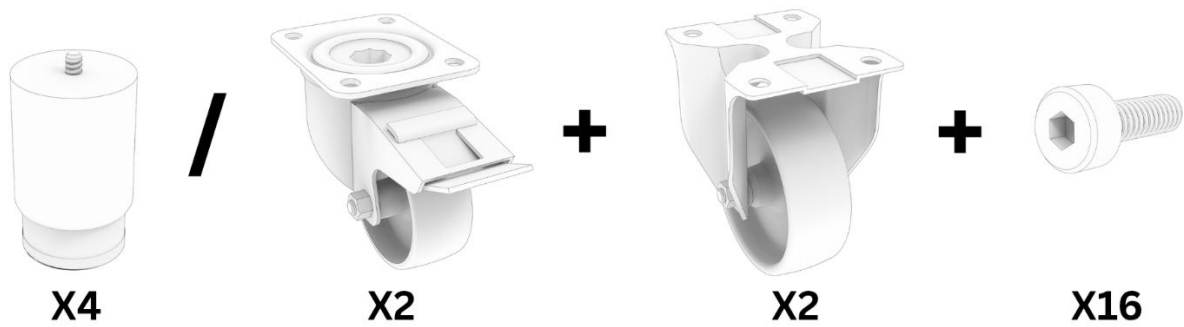

NB!

The tools mentioned in this manual can be replaced by similar power tools, if available. If power tools are used, it is very important:

- Not to use too large tightening torque
- To make sure that the metric screws going into the cabinet have been positioned correctly and have caught the thread properly prior to tightening the screws.



To take the cabinet of the transport pallet, two people are needed. The product is top-heavy, which does increase the risk of it falling over, when handled.

The cabinet is fixed to the pallet by two brackets placed respectively on the front next to the lower door hinge and in the diagonally opposite corner on the back of the cabinet. (See the illustration on the next page)

The product is released from the pallet by unscrewing the two TX20 wood screws in the pallet, using the supplied tool. These two TX20 screws are no longer needed and can be thrown away (See picture 1 in the illustration on the next page).

To remove the two transport brackets the two TX25 screws holding these are loosened, using the supplied tool (See picture 1 in the illustration below). When these screws have been loosened, the brackets can be removed (See picture 2 in the illustration below). These two brackets are no longer needed and can be thrown away. After removing the brackets, the TX 25 screws must be tightened again (See picture 3 in the illustration below).

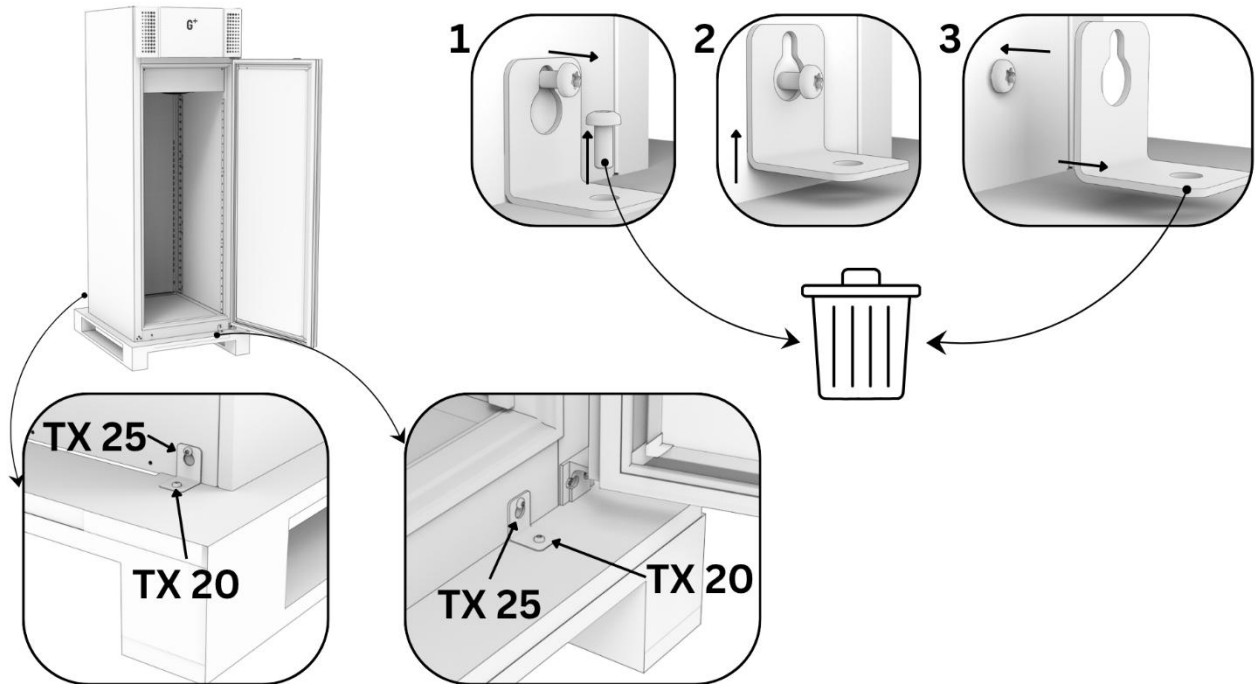

Next, move the product approx. 20 cm (8 inches) to the right over the side of the pallet (Front view). When this has been done, the product should be tilted approx. 30° to the left. When the product is stable in this position, it can easily be handled by one person, while the second person can start mounting legs or castors. Mounting of legs or castors is done using the supplied 6mm Allen key.

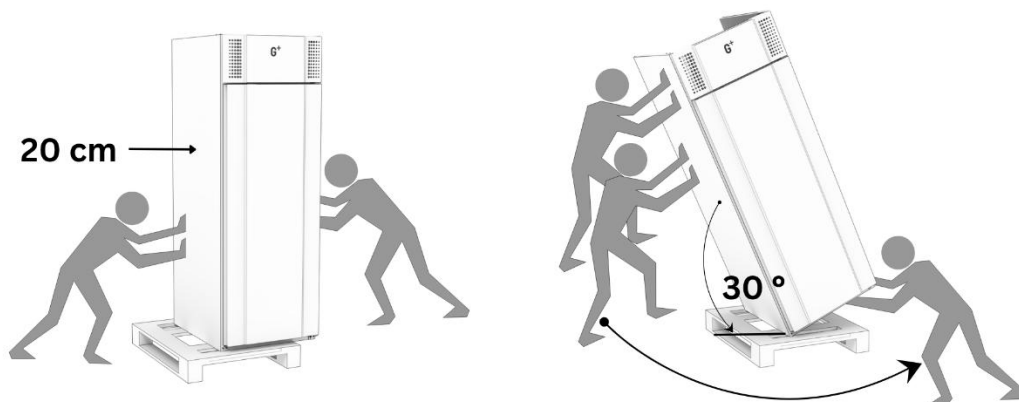

Mounting of legs or castors:

This is done using the 8mm bolt centred inside each leg or four short 8mm bolts per castor (supplied with the castor set).

For legs the long end of the 6 mm Allen key supplied is used to reach the bolt inside the leg (it is not necessary to take the leg apart to reach the bolt). The holes in the base plate where the legs are to be mounted are shown at the centre of the 5 holes, on the illustration below.

For castors the four 8mm bolts are fitted by hand and tightened using the 6 mm Allen key. The four holes in the base plate where the castors are to be mounted are shown at the periphery of the 5 holes, on the illustration below.

 **NOTE:** There are a few things that are important to do correctly to avoid dangerous situations. When installing the first two castors, it is important to install the rear straight-wheel first, so that it rolls front-to-back. Then install the swivel front castor, which is locked after installation, in the same direction as the rear wheel (see the illustration below).

The threads in the base plate should be free of foaming residues. If this is not the case it can be useful to press the Allen key approx.1 cm into the thread to remove / push back the foam.

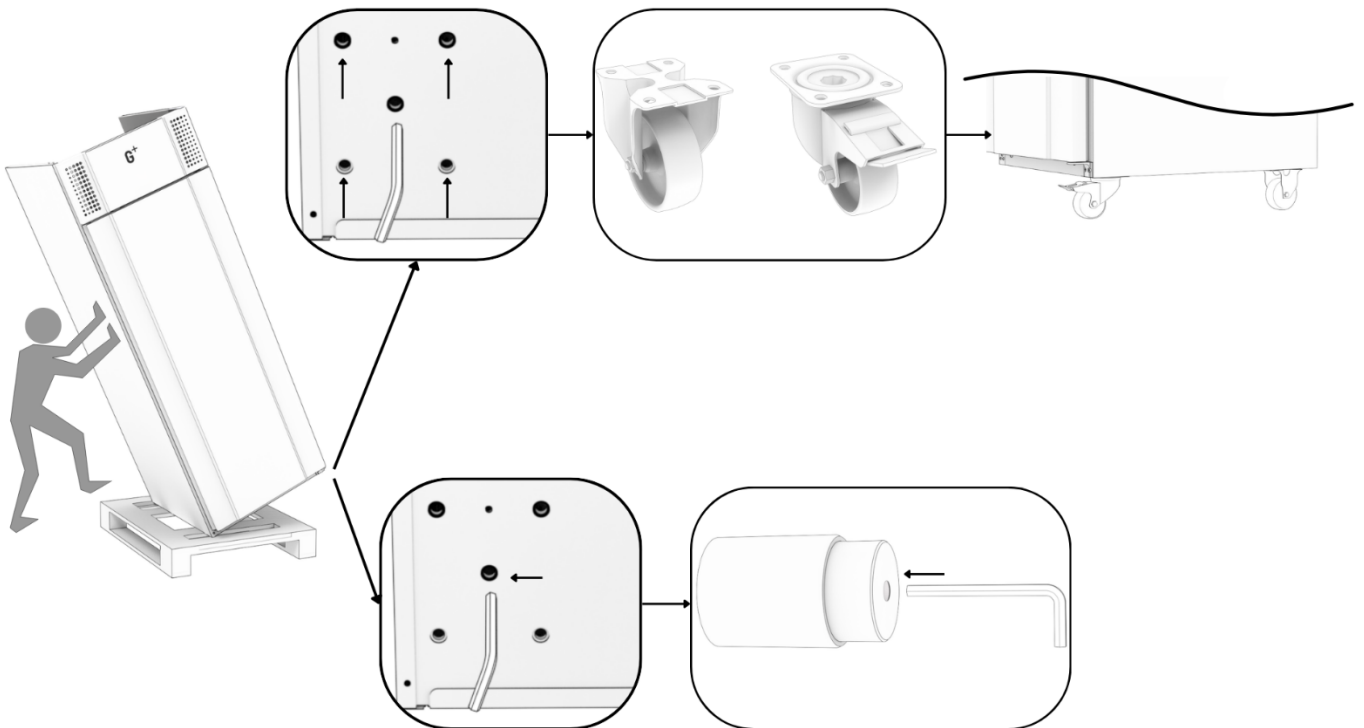

When the first two legs/castors have been mounted (part 1 of the illustration below), the two people help each other to tilt the cabinet from left to right (part 2 of the illustration below), so that the cabinet now rests on the two legs/castors just mounted. When the cabinet is stable, the second person can remove the pallet and mount the remaining two legs/castors in the same way as the first two (part 3 of the illustration below).



If the floor where this assembly is being carried out is very slippery / low friction, it is necessary to place something that increases friction between the legs or castors and the floor before tilting the cabinet (e.g. a rubber mat).

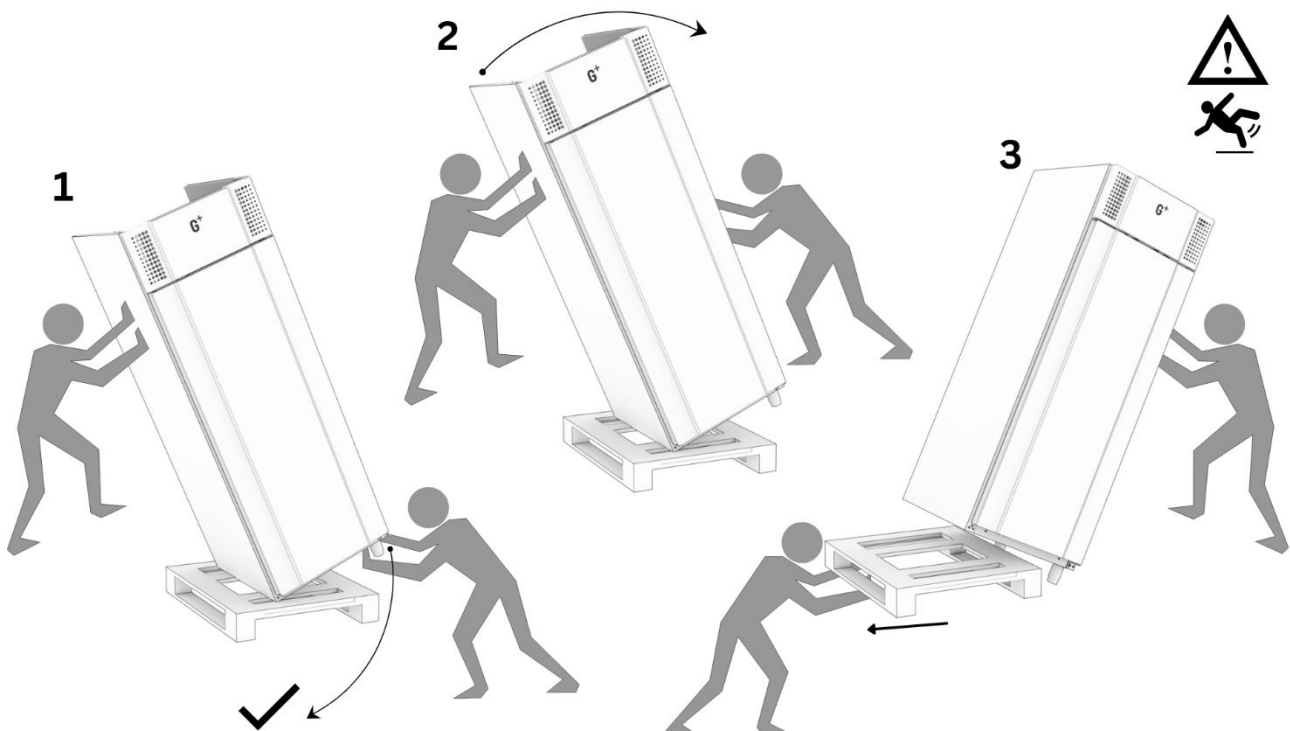

When all legs or castors have been mounted, the two people help each other to bring the product back upright. (shown in the illustration on the next page).

Mounting of pedal door opener (supplied ONLY WITH SUPERIOR products):

The pedal door opener is mounted by removing the four TX25 screws on the front of the cabinet, below the door on the handle side.

Mount the pedal door opener using the two upper screws (shown on the illustration on the next page)

(SUPERIOR)

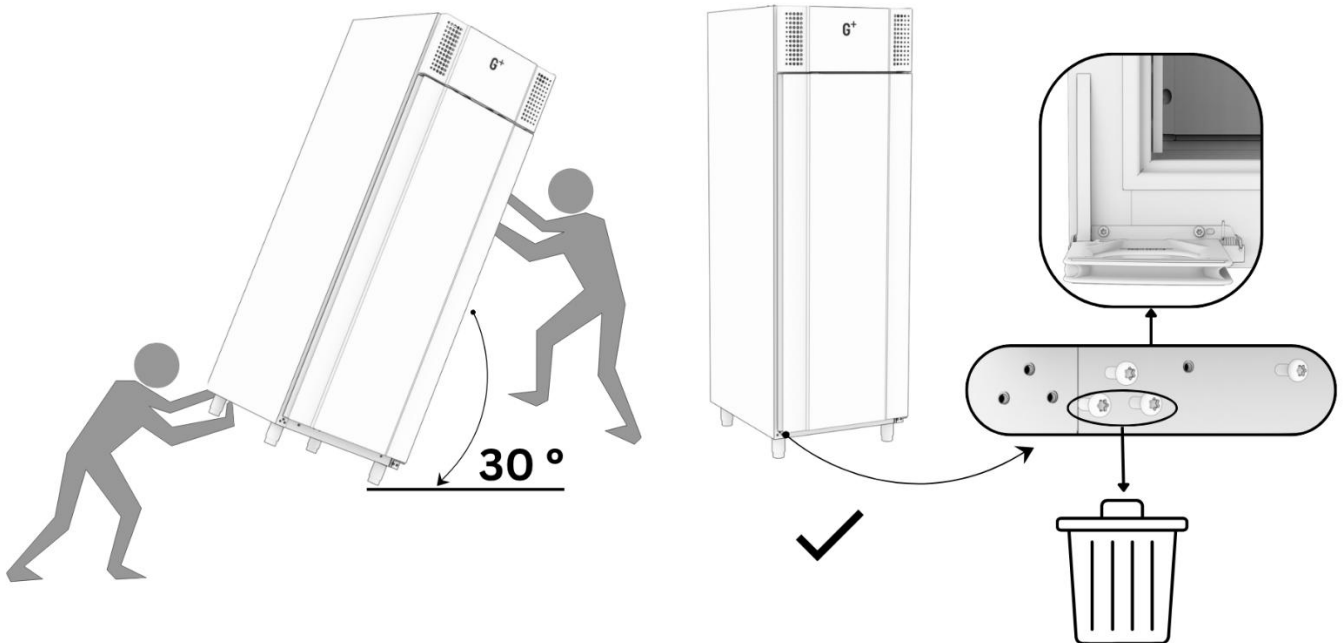

If the cabinet has been transported in horizontal position it must stand upright for at least 2 hours before it is turned on.

Because of the heavy weight of the product, the floor might be damaged or scratched when moving the product.

Correct set up gives the most effective operation.

The product should be in a dry and adequately ventilated room.

To ensure efficient operation, it may not be placed in direct sunlight or against heat-emitting surfaces. The product is designed to operate in an ambient temperature between +16°C and +40°C.

Avoid placement of the product in a chlorine/acid-containing environment (swimming bath etc.) due to risk of corrosion.

Parts of the product is equipped with a protecting film, which should be removed before use.

Clean the product with a mild soap solution before use.

The set-up place must be level and horizontal.

For versions with legs, use the adjustable legs to make sure that the product stands level and upright, see Fig.2.

For versions with castors, the locking devices of the two front castors must be activated, when the product is in place, see Fig.2. The base must be level, and the product may not be placed on frames or the like.

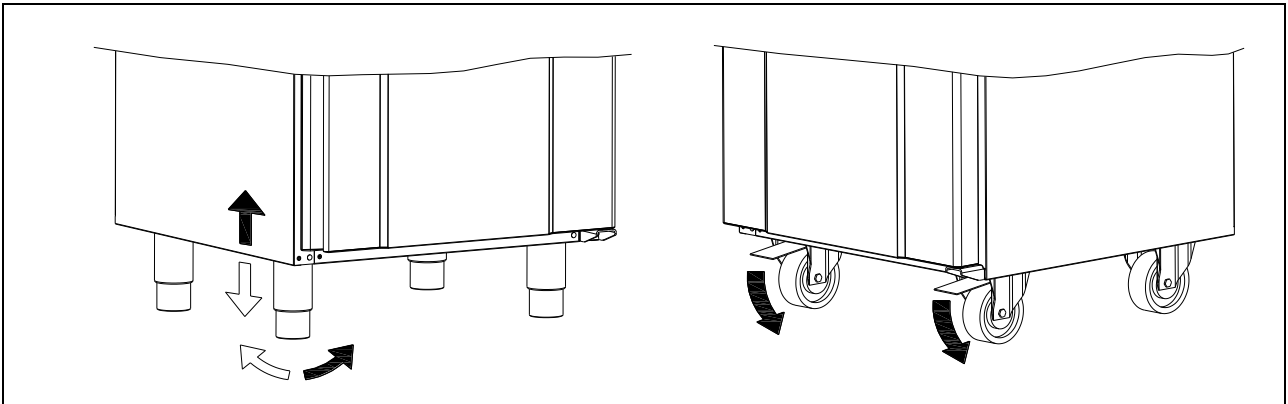

Fig. 2

It is ideal to install the product as close as possible up against the wall, however max. 75 mm from the wall.

There must be sufficient ventilation and free air circulation around the cabinet, as illustrated on Fig.3. There must be a minimum clearance of 250 mm above the cabinet, and 20 mm at the sides.

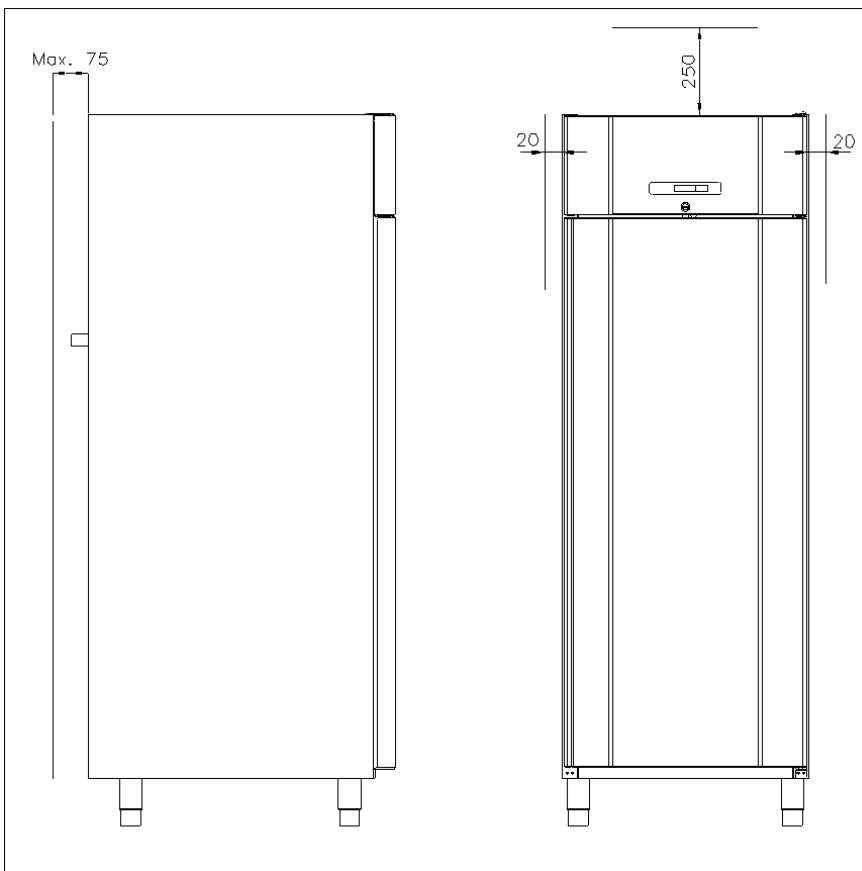

Fig. 3

Cabinets equipped with a glass door, must be fastened to a stable surface to ensure the cabinet does not tilt, when the door is open. Brackets for fastening are supplied with the cabinet (fasteners not supplied, use fasteners according to wall material/type).

See how to mount the brackets in Fig.4

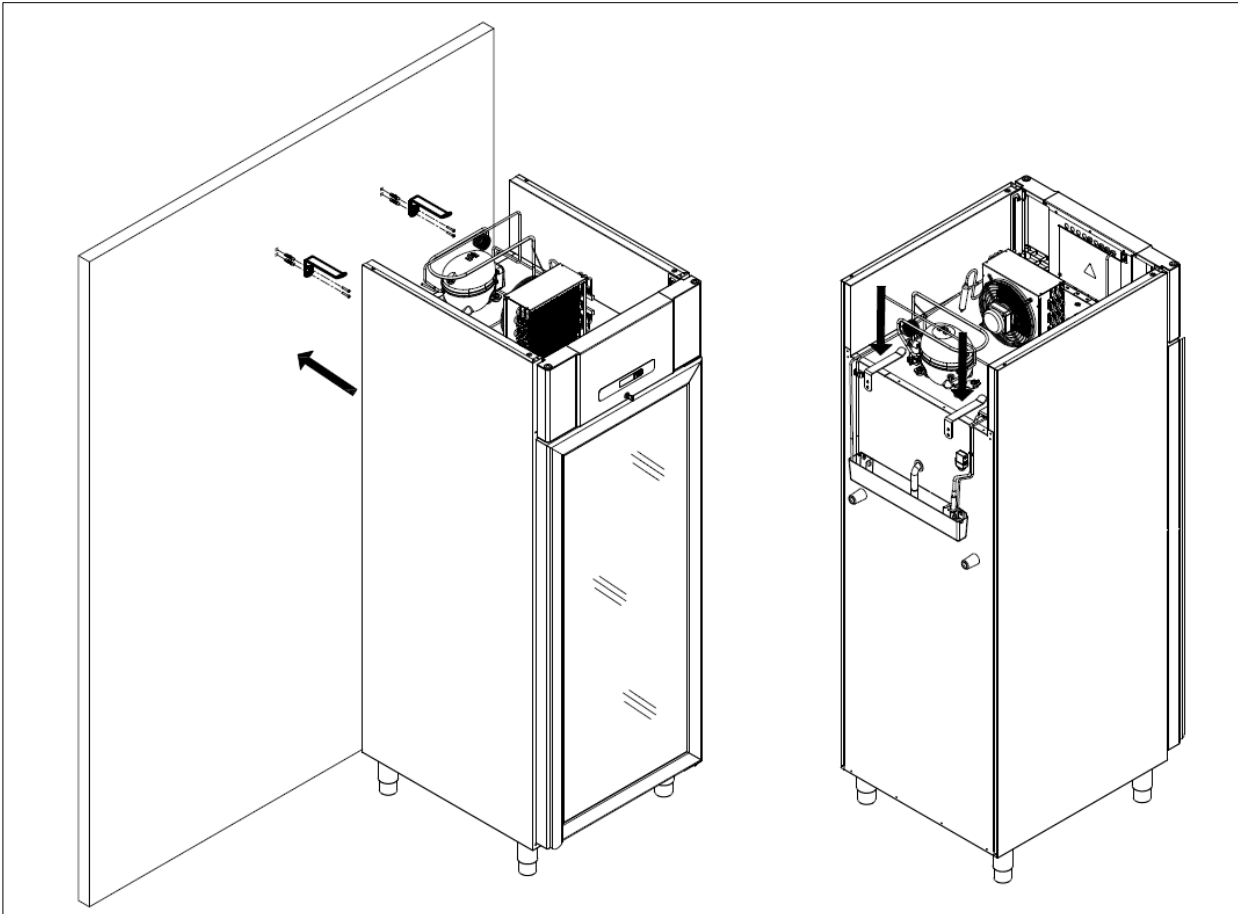

Fig. 4



To ensure that users, surroundings and stored items are not injured/damaged if the cabinets tilts, these brackets must be mounted.

Optimizing the energy consumption

- Correct set up gives the most effective operation.
- The product should be located in a dry and adequately ventilated room.
- To ensure efficient operation, it may not be placed in direct sunlight or against heat-emitting surfaces. The product is designed to operate in an ambient temperature between +16°C and +40°C.
- Do not keep the door open for too long.
- Do not set the temperature setpoint too low.
- The product should be placed as close as possible up against the wall.

General description

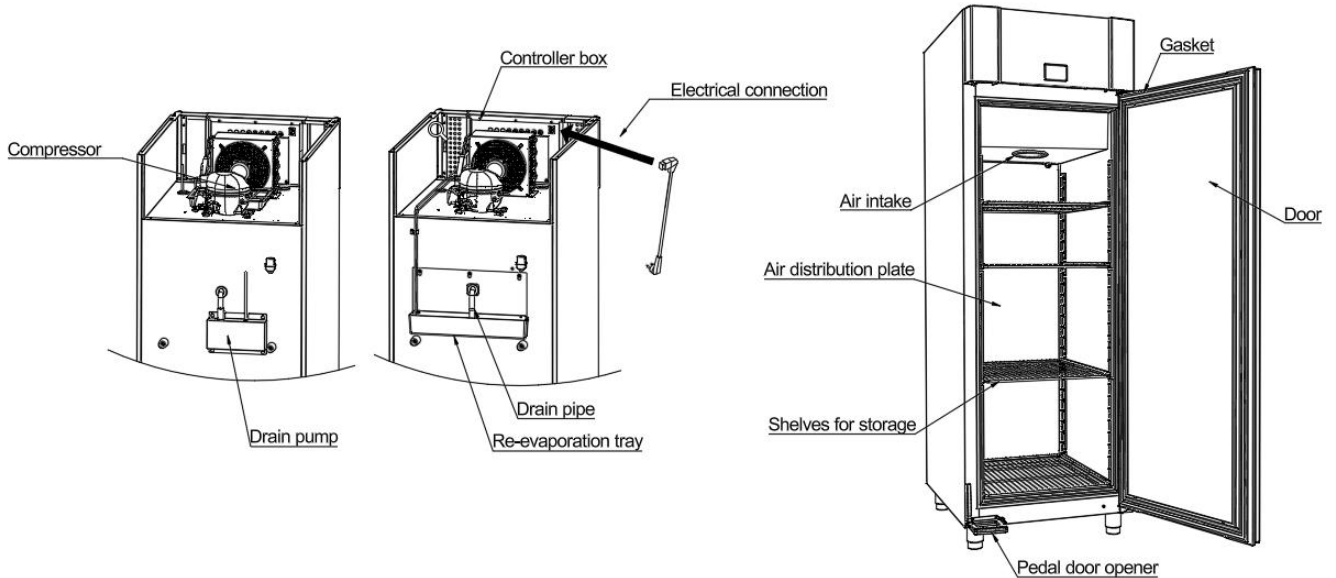

Fig. 5

Refrigerant / GWP value

Refrigerators	Refrigerant	Charge kg	GWP	CO ₂ Equivalent t
Maxi Eco R/C 700	R290	0,078	3	0,000234
Maxi Superior C 700	R290	0,078	3	0,000234
Freezers				
Maxi Eco F 700	R290	0,058	3	0,000174
Maxi Superior F 700	R290	0,058	3	0,000174

Climate / temperature class

Products are tested according to the following climate and temperature classes. Information about the product's climate and temperature class can be found on the name plate (see fig. 8)

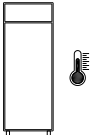
Climate class	
	
4	30°C / 55 % RH
5	40°C / 40 % RH

Temperature class	
	
L1	-18°C
M1	+5°C

Electrical connection

Read the text below thoroughly before electrical connection.

Connect the detachable power cord to the main supply inlet, on the back of the controller box (see fig. 5 page 13) where it is named “Electrical connection”. Only the supplied cord is to be used.

The power cord is found in the top compartment, behind the packaging label on the back of the cabinet like shown below:

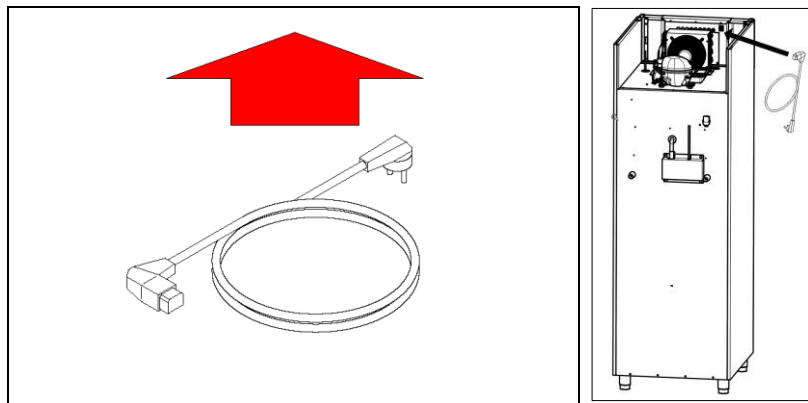

The product is intended for connection to alternating current. The connection voltage (V) and frequency (Hz) are shown on the name plate (see Fig.7 page 26).



Never use an extension cord for this appliance!

If a wall socket is placed in a longer distance than the length of the supplied power cord, contact an electrician to establish a wall socket within the range of the supplied power cord.



If the product is defective, it must be examined by a properly skilled technician with proper knowledge of the product.

During the warranty period:

Call your dealer to arrange for service.

Outside the warranty period:

It is advisable to use the service advised by your dealer. If this is not the case, assistance is required from a properly skilled technician with proper knowledge of the product.

Always disconnect the power if interruptions in power supply occur, and when electrical parts are removed/put on, and before cleaning and maintenance of the product.

Repairing of electrical/technical parts may only be performed by properly skilled technicians with proper knowledge of the product.

Do not use the product before all coverings are installed, so that live or rotating machine parts cannot be touched.

The product is not to be used outdoor.

All earthing requirements stipulated by the local electricity authorities must be observed. The plug and wall socket should then give correct earthing. If necessary, contact an electrician.



Make sure the product is switched off at the socket before service is performed on electrical parts. It is not sufficient to switch off the product by the START/STOP key as there will still be power to some electrical parts of the product.

General use



Do not damage the refrigeration system parts.



During normal operation, some parts of the refrigeration system in the compressor compartment might reach high temperatures and could therefore cause burns if touching these components.



Do not use electrical devices inside the product.



To ensure correct and efficient air flow in the cabinet, the shaded areas must be kept free of items (see Fig. 6 page 16).



All items to be stored, that are not wrapped or packed, must be covered to avoid unnecessary corrosion of the inner parts of the cabinet.



If any controller parameters are changed from default, this could cause that the product is not functioning normally, and harmful temperatures could damage items that are kept inside the product.



If the product is turned off, wait minimum 3 minutes before turning it on again. This is to prevent compressor damage



Maximum loading of wire shelf: 40 kg



Do not store explosive substances such as aerosol cans with flammable propellant in this appliance.

Be aware, if bottles are stored near the air outlet, they may freeze up and break, causing a risk of injury (only R, C and GR products).

Do not overpack the product with foods. Allow some space between them to ensure adequate airflow.

Moist or fresh foods and those with a strong smell should be wrapped in cling film or packed in a container. Otherwise, the food may dry out or give their smell to other foods.

Foods containing acetic acid or yeast should be wrapped in cling film. Otherwise, they may accelerate corrosion of the evaporator and metal parts, resulting in failure.



To ensure correct and efficient air flow in the product, the shaded areas and the area above the top load line must be kept free of items. (see Fig. 6)

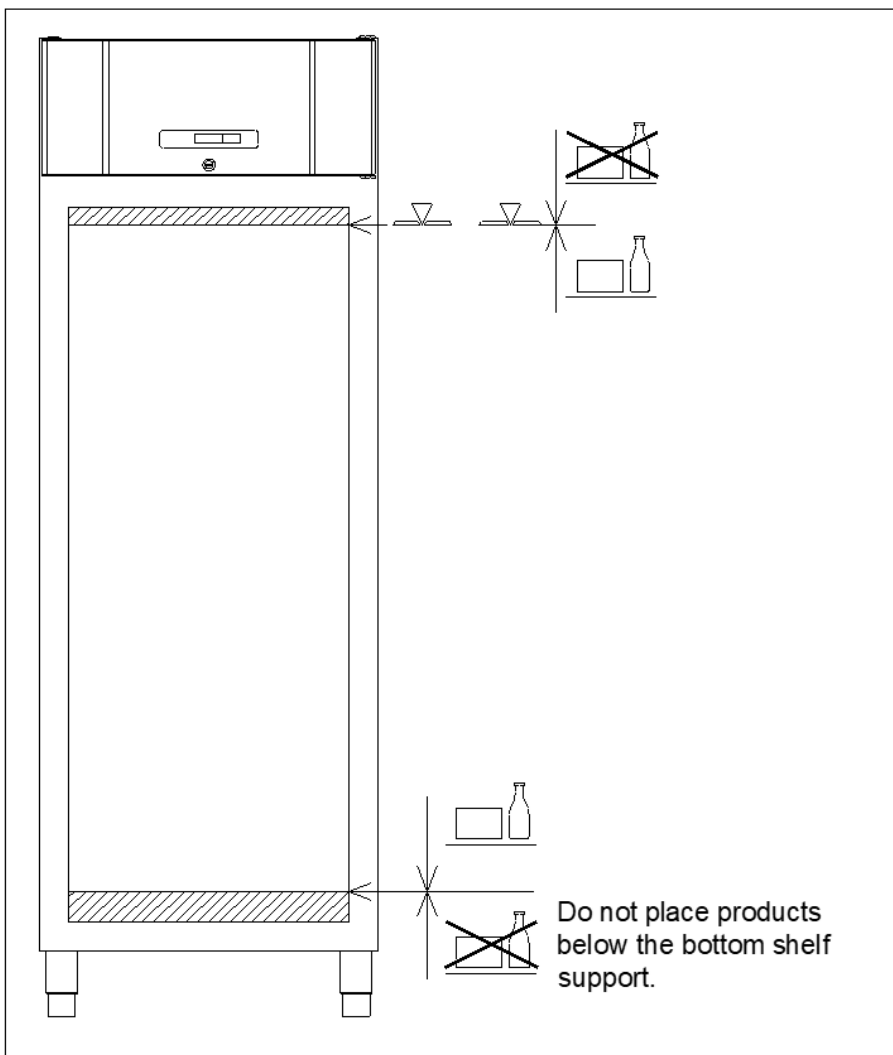
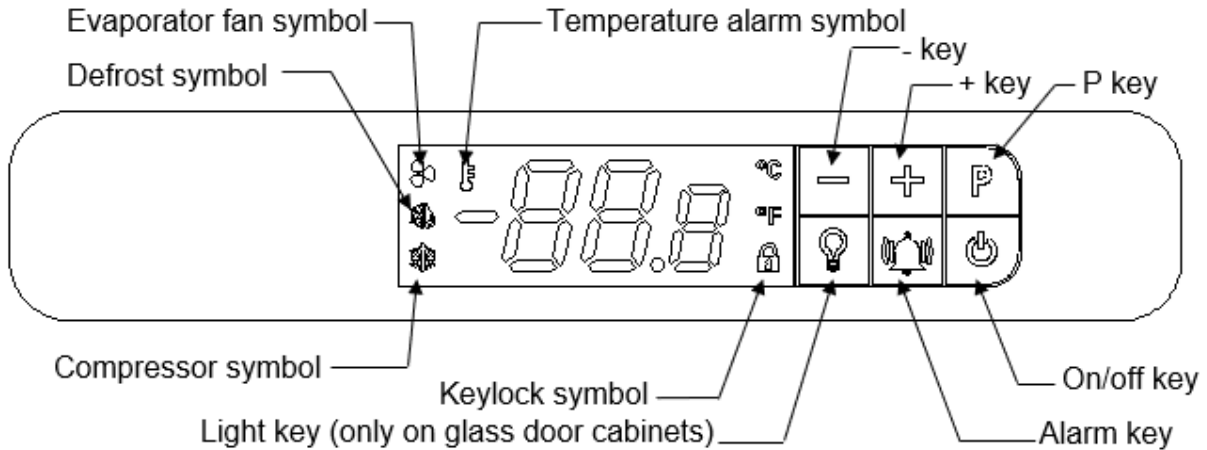

Fig. 6

Operating the product

Display overview



When the product is connected to main supply a short boot sequence is performed. During this all light-segments in the display are lit.

After that, the controller starts up in normal operation mode.

If the cabinet is not turned on when connecting it to main supply, the display will show OFF.

To turn the cabinet on, push and hold  for 5 seconds.

The controller starts up in normal operation mode displaying the current cabinet temperature.

The refrigeration system will follow the factory default set temperature:

For refrigerators (R and GR) the set temperature is 5°C (adjustable from 2 to 12°C)





For refrigerators with extended temperature range (C) the set temperature is 5°C (adjustable from -5 to 12°C)

For freezers (F) the set temperature is -18°C (adjustable from -5 to -25°C)

To turn the cabinet off, push and hold  for 5 seconds.

Control lights

The following control lights are located on the display:

	Compressor symbol. This LED is on while the compressor is running. Flashes during temperature setting.
	Defrost symbol. This LED is lit during the defrosting cycle.
	Evaporator fan symbol. This LED is on while the evaporator fan is running.
	Temperature alarm symbol. This LED is on if a temperature alarm occurs.

Keylock

When  is lit, the display keys are locked. This is done to avoid unintended adjustments or turning off the cabinet, during cleaning or similar. It is a prerequisite for any control settings that the display is unlocked.



To unlock the keys:



Push and hold any key for 5 seconds to unlock the controller keys. When the controller has been successfully unlocked,  turns off.

Automatic keylock:

Not touching the controller for two minutes, will automatically activate the keylock.

Adjusting the cabinet temperature

To change the set temperature, push  once,  flashes, and the current set point is shown in the display, with one decimal place after the comma.

Push  or  to change the temperature set point. The new set point temperature is confirmed/saved by pushing  once. The display returns to normal operation.

To exit without change push  once, or do not touch any key for 60 seconds

After power failure the controller returns to stored settings.

Dry cooling

(This function is only available on C – cabinets)

Know that turning on dry cooling (DC) will lower the RH% inside the cabinet. This function should only be used when intended – as this will draw our moisture which can result in some food being damaged.

When the cabinet is supplied, (DC) is not activated. To activate (DC), the following must be done:

Push and hold  for 5 sec. When the 5 sec. have elapsed, a small “d” is lit in the decimal segment - indicating (DC) being activated.

De-activation of (DC) is done in the same way (the small “d” will be turned off).

Setting temperature alarm parameters



Adapting the below parameters to suit the real conditions of use, it is important to ensure that the settings do not make the alarm system either too sensitive or too insensible.

Adjusting the difference between temperature set point and **hAL** / **LAL** alarm settings too narrow, will result in unintended alarms. A narrow gab combined with a too short **dAh** could result in an **AH** alarm, just by opening the door.

dAh should never be adjusted to less than 30 minutes.

To access the temperature alarm parameters, push and hold  and **P** simultaneously for 5 seconds. The display will flash the first temperature alarm parameter **hAL**.

To access the individual parameters, push **P**.

To move between and adjust the parameters use  and .

Push **P** to store the new setting. The controller automatically jumps to the next parameter.

Adjustable parameters are:

		Factory default	
hAL	High Alarm Limit		+ 25° C
LAL	Low Alarm Limit		- 29° C
dAh	Time delay Alarm high	120 minutes	
dAL	Time delay Alarm Low	20 minutes	
Atd	Alarm temperature differential	2K	

The above parameter settings will result in the following:

To trigger a high temperature alarm (**Ah**) the cabinet temperature must be above **hAL** = 25°C for more than **dAh** = 120 minutes. This will result in  being lit and the display alternating between **Ah** and the present cabinet temperature.

Once the temperature goes below 23°C (**hAL – Atd**) the alarm changes from present to being logged. The display will show current temperature and  will remain lit indicating there has been a temperature alarm.

To trigger a Low temperature alarm (**AL**) the cabinet temperature must be below

LAL = - 29°C for more than **dAL** = 20 minutes. This will result in  being lit and the display alternating between **AL** and the present cabinet temperature.

Once the temperature goes above -27°C (**LAL + Atd**) the alarm changes from present to being logged. The display will show current temperature and  will remain lit indicating there has been a temperature alarm.



Temperature alarms

The following temperature alarms can be displayed:

Ah Alarm high temperature

AL Alarm Low temperature

If an alarm occurs, **Ah** or **AL** will be shown alternating with the current temperature.

If the temperature gets back within the accepted limits, the current temperature will be shown in the display and  will remain lit until the alarm has been reset. After 3 days  will be turned off, but the alarm will still be kept in the alarm log.

Displaying alarms:

The temperature alarm log stores information related to the latest 10 temperature alarms (named A 1 to A10). If a new alarm occurs the oldest alarm (A10) will be erased.



Push  once to open the log.

- If there is no present or logged temperature alarm the display will show “no” flashing for 4 seconds. After that the controller will revert to normal operation.
- If there are present or logged temperature alarms the display will show the most recent temperature alarm being:

A 0 Present / ongoing temperature alarm.

A 1.. A10 Not present temperature alarms logged

Once the cabinet temperature, related to a present temperature alarm (A 0), is no longer outside the alarm ranges, this A 0 alarm becomes the new A 1. Etc.

Use  and  to navigate between the different alarms.

Push  to open a temperature alarm in order to show:

Example 1 – alarm A 0: (Present temperature alarm)

Ah Indicating it is a high temperature alarm (AL indicating a low temperature alarm)

8.0 the maximum temperature in °C during the alarm (If AL the minimum temperature)

dur alarm duration until now





01h the alarm has been ongoing for 1 hour

15' and 15 minutes

Example 2 – alarm A1 to A10: (alarms in the log – not present)

Ah Indicating it is a high temperature alarm (AL indicating a low temperature alarm)
9.0 the maximum temperature in °C during the alarm (If AL the minimum temperature)
dur alarm duration
01h the alarm lasted for 1 hour
15' and 15 minutes
tSE time since the end of the alarm
08h the alarm ended 8 hours ago (maximum 99 hours)
Each value is displayed alternately for approx. 1 second.
It is not possible to reset or delete a present temperature alarm A 0

Resetting alarm symbol 

Look through all non-present alarms, after each alarm Push  to verify having seen the alarm. To exit an alarm without verifying, push . Once all alarms have been verified,  will turn off, unless there is a present alarm.
Push , to leave alarm log.

Deleting alarms:

Push  once to open the log.

Display shows A 1. Delete all non-present temperature alarms by holding  for 5 seconds. Once the alarm log is deleted the display flashes “ - - - ” for 3 seconds.

Messages and alarms shown in the display

- OP** **OP** shown constantly, indicates door open. If alternating with temperature, door has been open for more than 2 minutes. Close the door and **OP** will disappear.
- d** a small “d” is lit in the decimal segment, after the temperature e.g. **5d** - indicating Dry cooling being activated (only possible on C -Cabinets). For explanation see under Dry Cooling.
- E1** **E1** indicates defective room sensor. Monitor temperature until replaced.
Request service assistance immediately.
- E2** Alternating between **E2** and temperature indicates a defective evaporator sensor. On freezers an **E2** failure can also occur if the evaporator is heavily iced up. Defrosting will be time-based.

In some cases, E.G. if the door has not been closed correctly or has been opened too frequently for too long, the reason for an **E2** failure, on a freezer, can be a total ice up of the evaporator. Try performing manual defrosting (Look under defrosting to see how this is done). This might solve the problem.

If spare freezer capacity is available, one can also try to move the frozen food to an alternative freezer and then to turn the freezer off overnight and leave it with the door open. This should however only be done if the cabinet is placed on a floor surface like concrete or tiling which can withstand water, as this kind of defrosting, in rare cases, can result in a re-evaporation tray overflow. If none of these alternatives solve the problem **Request service assistance immediately.**

Ah Alarm high temperature – See explanation under temperature alarms

AL Alarm Low temperature – See explanation under temperature alarms

Defrosting

During defrosting when the defrosting symbol  is lit, one should avoid or at least minimize the number and the duration of door openings, as the refrigeration system is forced off during defrosting.

R and GR cabinets:

Defrosting is automatically performed by air 4 times every 24 hours.  is lit.

C cabinets

Defrosting is automatically performed 4 times every 24 hours by either air or heating element depending on controller settings.  is lit.

F cabinets:

Defrosting is automatically performed 4 times every 24 hours.  is lit.

Manual defrosting:

If operating with frequent door opening and replenishment, manual defrosting can be necessary. Manual defrosting is started by holding  for 5 seconds.

Troubleshooting

Noise:

- If abnormal noise occurs, request service assistance.
- Operating sounds from compressor, condenser fan and interior fan are normal.

Frosting inside compartment:

- Ambient humidity too high.
- The door is opened too often.
- The door is left open for too long.

- Damaged door gasket. Check it thoroughly for damages.

Poor cooling performance:

- Ambient temperature is too high.
- The door is open too often and/or open for too long.
- The door is left open.
- Damaged door gasket.
- Temperature setting too high.
- Product too packed with foods - air inlet/outlet blocked.
- Warm or hot foods inside the product.
- Defrost in progress. The cabinet temperature may rise temporarily during the defrost cycle, but it will not affect the food inside. The defrost symbol  is displayed.

Some of the foods are frozen:

- Product too packed with foods - air inlet/outlet blocked.
- Temperature setpoint too low.
- Evaporator fan might be defective.

Condensation around the door:

- Ambient humidity is too high.
- The door is not closed tightly.
- Damaged door gasket.

Draining water or ice formation inside the back wall / bottom:

- Check that the drain is not blocked.
- Check and clean the water trap in external re-evaporation tray.

Defrost water

Water drains out to the rear of the cabinet during defrosting.

On (R/GR or C cabinets) the drain water coming out of the cabinet, is pumped into a re-evaporation tray on the top of the cabinet placed between the compressor and the condenser. Furthermore, there is a hot gas pipe in this tray to accelerate the re-evaporation.

On freezer cabinets a re-evaporation hot gas pipe from the refrigeration system, placed in tray on the rear of the cabinet, re-evaporates the water. (see Fig.5 page 13).



It is recommended to clean the re-evaporation tray and water trap when necessary - at least once a year. Remember to disconnect the cabinet before cleaning.

Be careful not to damage the re-evaporation pipe and the pump on fridges during cleaning.

Light - solid door

The light on solid door cabinets is positioned in the top panel above the door. It is controlled by door openings.

Door open = light on
Door closed = light off

Light - glass door

The light in the glass door, can be switched to work in two different ways. Light constantly on (Lco) or light off when door closed (Ldo).

Push and hold  for 5 seconds to change between Lco and Ldo. Default setting for glass door cabinets is Lco.

Power failure

In the event of a power failure, the controller remembers the temperature setting and restarts the product when power is restored. If the power failure persists for very long time, the control might revert to the factory setting. Do always check the temperature set point if in any doubt.

Cleaning

Insufficient cleaning will cause that the product will not work at optimum performance, or eventually it will be defective.



Before cleaning, the product should always be disconnected.



Do not flush the product with water, do not use water hose, water jet or steam hose as this may cause short-circuits in the electrical system.



Cleansing agents containing chlorine or compounds of chlorine as well as other corrosive means, **are not to be used**, as they might cause corrosion to the cabinet and the refrigeration system.



The compressor compartment and in particular the condenser must be kept free from dust and dirt. This is best done with a vacuum cleaner and a brush.



For the external maintenance and cleaning – Use a hot soapy damp cloth. After cleaning rinse off with a moist cloth only containing water. Finalize the cleaning by wiping the cabinet dry, using a dry cloth. Cabinets with stainless steel exterior, should be treated with stainless steel polish at the end.



The product should be cleaned internally with a mild soap solution at suitable intervals and checked thoroughly before it is put into operation again.

Door gaskets

This chapter deals with the importance of a well-functioning door gasket.

The door gasket is an important part of a refrigerator/freezer. A door gasket with reduced functionality, reduces the seal between the cabinet inside and the ambient environment. This might cause increased internal humidity resulting in an iced-up evaporator (leading to reduced refrigeration capacity), and in worst case reduced lifecycle of the cabinet.

Therefore, it is important to be aware of the condition of the gasket. Regular inspection is recommended.

The gasket should be cleaned regularly with a mild soap solution.

If a gasket needs replacement, contact your dealer.

Long term storage

If the product is taken out of operation, and need to be prepared for long-term storage, clean the inside compartment, the door and door gasket thoroughly with a hot soapy damp cloth.

Eventual remnants of food do create mold.

It is advisable to leave the cabinet door open during long term storage, to minimize the risk of bad smell and the building of mold inside the cabinet. Keeping the door open should not be done by putting something between door and cabinet, unless this does not affect the door gasket. If this is not taken into consideration it could result in non-reversible deformation of the door gasket.

Service

The refrigerating system and the hermetically sealed compressor require no maintenance - they merely must be kept clean.

If refrigeration fails, first investigate whether the unit has been unintentionally disconnected or switched off at the socket, or whether a fuse has blown.

If it is not possible to find the cause of the refrigeration failure, please contact your dealer.

When reporting a malfunction please state the type, the production year and week YYYY - WW and the 8-digit serial number (S/N) of the cabinet. These information are found on the name plate, placed like stated below and shown on Fig. 7.

Positioning of the name plate

To give the dealer a fair chance of identifying the product, it is highly recommended to take a picture of the name plate, prior to calling for service.

The name plate info mentioned in the above paragraph are needed to identify the product, to service you in the best possible way.

The name plate on these products is placed inside the food compartment in the top left side as shown below (see Fig. 7)

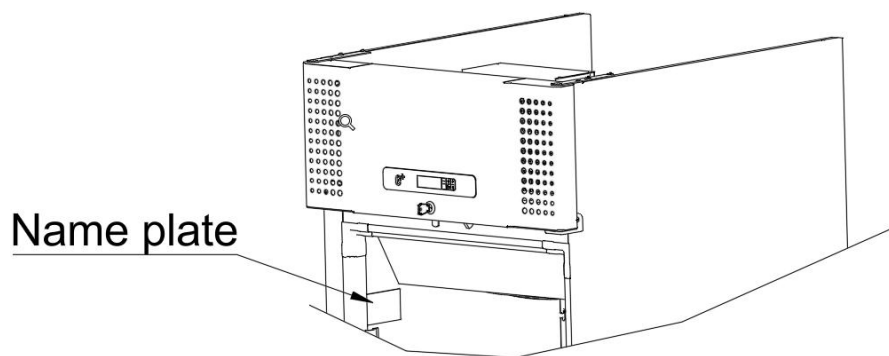

Fig.7

Disposal

Electrical and electronic equipment (EEE) contains materials, components and substances that can be dangerous and harmful to human health and the environment if the waste (WEEE) is not disposed of properly.

Products that are labelled with a “crossed-out wheelie bin” is considered electric and electronic equipment. The crossed-out wheelie bin symbolizes that waste of this type cannot be disposed of with unsorted municipal waste but must be collected separately. Contact your local dealer when the product needs to be disposed of.

Please be aware of not damaging the refrigeration system and piping when a product is taken out of use. This will prevent the uncontrolled escape of the refrigerant from the refrigeration system.

The below only concerns the United Kingdom.

Disposal of an old cabinet is only available when we are delivering a new one at the same time. Cabinets must be fully defrosted and emptied prior to collection.

Gram Professional recognises that our products for the catering market are considered WEEE when they become obsolete. To ensure that Gram Professional responsibilities are handled correctly and environmentally friendly, we are signed up the largest Business to Business compliance scheme in the UK – B2B Compliance
<http://www.b2bcompliance.org.uk>

B2B Compliance will on our behalf deal with all areas of our responsibilities when collecting and disposing of equipment which fall under the UK WEEE regulations. B2B Compliance can be contacted on telephone number 01691 676124.



Declaration of conformity

EC-Declaration of conformity

Producer Name: Gram Scientific ApS. (CVR No. 43122193)
Address: Aage Grams Vej 1, 6500 Vojens
Tel.: 0045 73 20 13 00

Product Model: R/C/F/GR 510, R/C/F/GR 700
R/C/F/GR 710, R/C/F/GR 600,
R/C/F/GR 1400, Combi Twin 710
Eco R/C/F 700, Superior C/F 700
Refrigerant: R290, R600a
Year: 2023

Directives The product is in compliance with all the essential health- and safety requirements and provisions in:
Directive for Machinery 2006/42/EF
The product is where relevant in compliance with the following other directives:
Electromagnetic Compatibility Directive – 2014/30/EU
Design of energy related products 2009/125/EF
Regulation 2015/1095
FCM regulation 10/2011
Regulation 1935/2004
RoHS 2 - 2011/65/EU
RoHS 3 - (EU) 2015/863

Standards The following standards are used to the extent necessary to comply with the relevant directives:
DS/EN 12100:2011 - Safety of machinery -- General principles for design -- Risk assessment and risk reduction
DS/EN 60335-1:2012 – Household and similar electrical appliances. Safety. General requirements
DS/EN 60335-2-89:2010 – Household and similar electrical appliances. Safety. Particular requirements for commercial refrigerating appliances with an incorporated or remote refrigerant condensing unit or compressor

Person responsible for technical dossier Company: Gram Scientific ApS. (CVR No. 43122193)
Address: Aage Grams Vej 1
Name: John Lund

Signature Vojens 19/01-2026 R&D Manager 

UKCA/UKNI-Declaration of conformity

Producer Name: Gram Scientific ApS. (CVR No. 43122193)
 Address: Aage Grams Vej 1, 6500 Vojens
 Tel.: 0045 73 20 12 00

Product Model: R/C/F/GR 500, R/C/F/GR 700
 R/C/F/GR 710, R/C/F/GR 600,
 R/C/F/GR 1400, Combi Twin 710
 Eco R/C/F 700 / Superior C/F 700

Refrigerant: R290, R600a

Year: 2023

Directives The product is in compliance with all the essential health- and safety requirements and provisions in:

Directive for Machinery 2006/42/EF

The product is where relevant in compliance with the following other directives:

Electromagnetic Compatibility Directive – 2014/30/EU

Design of energy related products 2009/125/EF

Regulation 2015/1095

FCM regulation 10/2011

Regulation 1935/2004

RoHS 2 - 2011/65/EU

RoHS 3 - (EU) 2015/863

Standards The following standards are used to the extent necessary to comply with the relevant directives:

EN 12100:2011 - Safety of machinery -- General principles for design -- Risk assessment and risk reduction

EN 60335-1:2012 – Household and similar electrical appliances. Safety. General requirements

EN 60335-2-89:2010 – Household and similar electrical appliances. Safety. Particular requirements for commercial refrigerating appliances with an incorporated or remote refrigerant condensing unit or compressor

Responsible Company: Gram Scientific ApS. (CVR No. 43122193)
Technical File Name: R&D Manager John Lund

Signature Vojens 19/01-2026

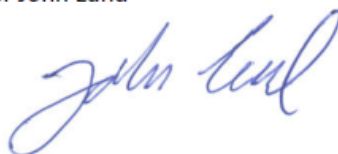

Wiring diagram – Eco R/C 700 – Superior C 700

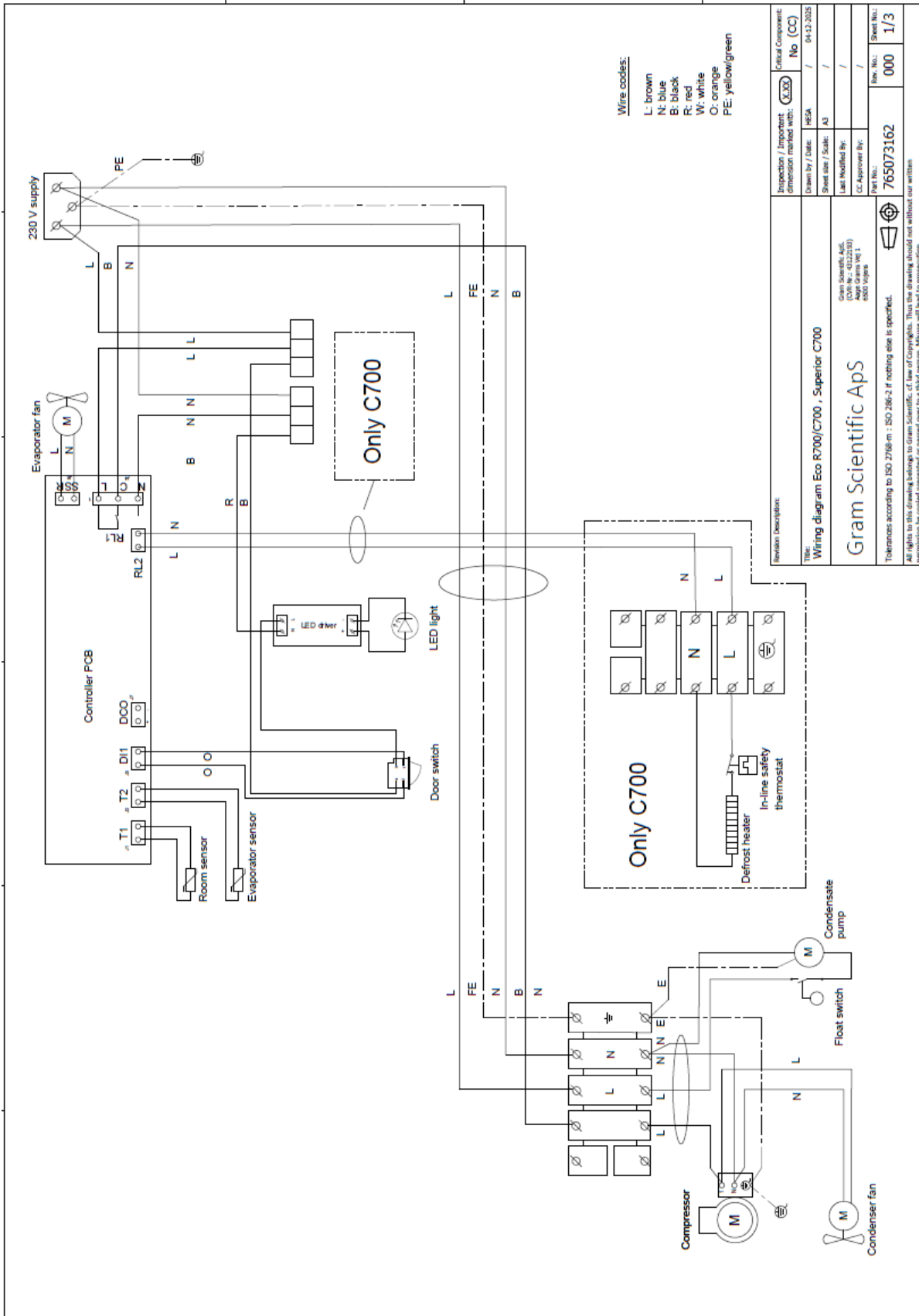

Wiring diagram – Eco/Superior F 700

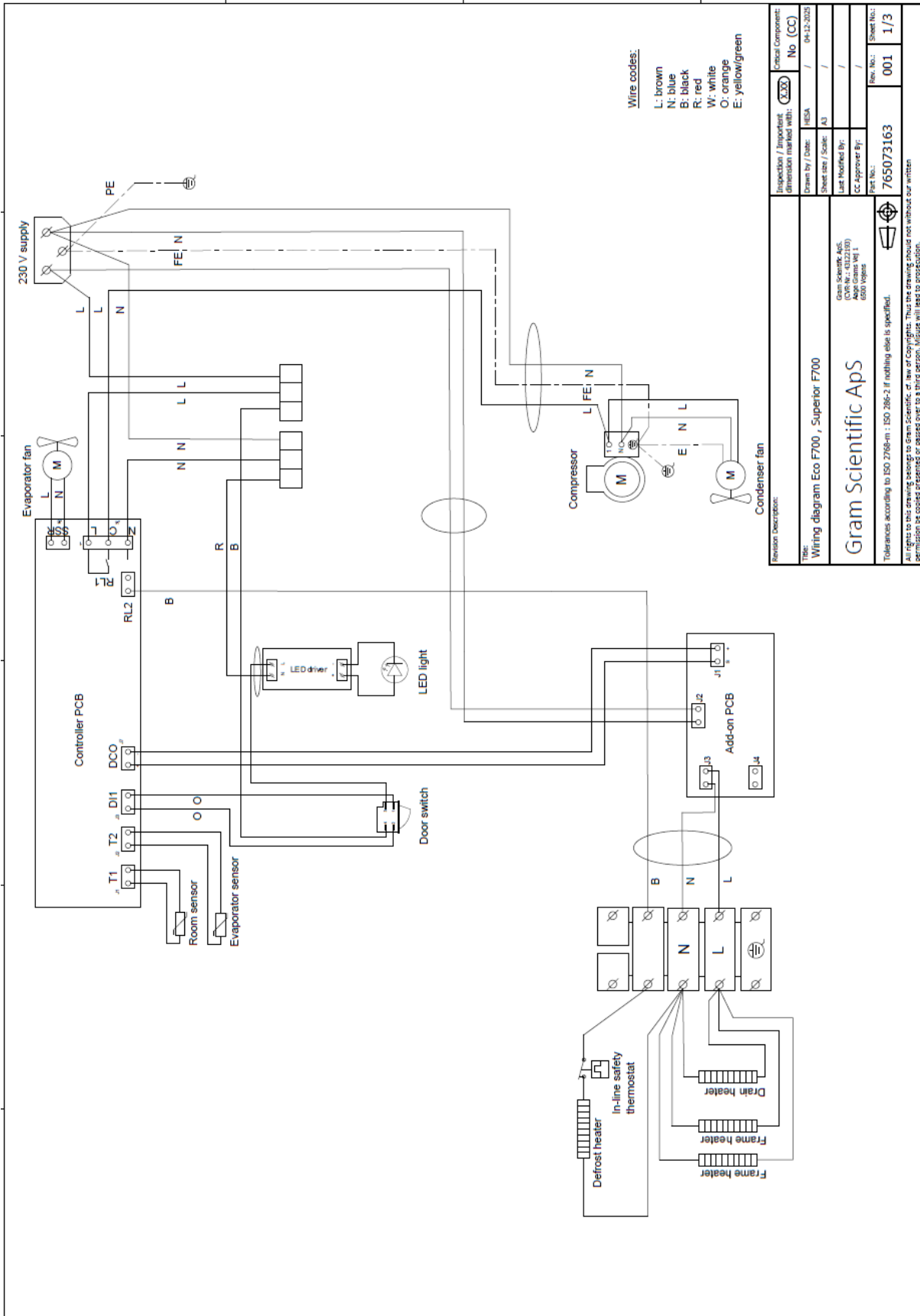

Revision Description:		Inspection / Important dimension marked with: (XXX)	Critical Component: No (CC)
Type: Wiring diagram Eco F700, Superior F700		Drawn by / Date: HESA / 04-12-2023	Sheet size / Scale: A3 /
Gram Scientific Aps. (OVR-Nr.: 4312183) Apt. No.: 4011 6500 Viborg		Last Modified By: /	CC-Approver By: /
Tolerances according to ISO 2768-m; ISO 286-2 if nothing else is specified.		Part No.: 765073163	Rev. No.: 001
All rights to this drawing belong to Gram Scientific, or law of Copyright. This drawing should not without our written permission be copied, presented or passed over to a third person. All data will need to be protected.		Sheet No.: 1/3	

Piping diagram

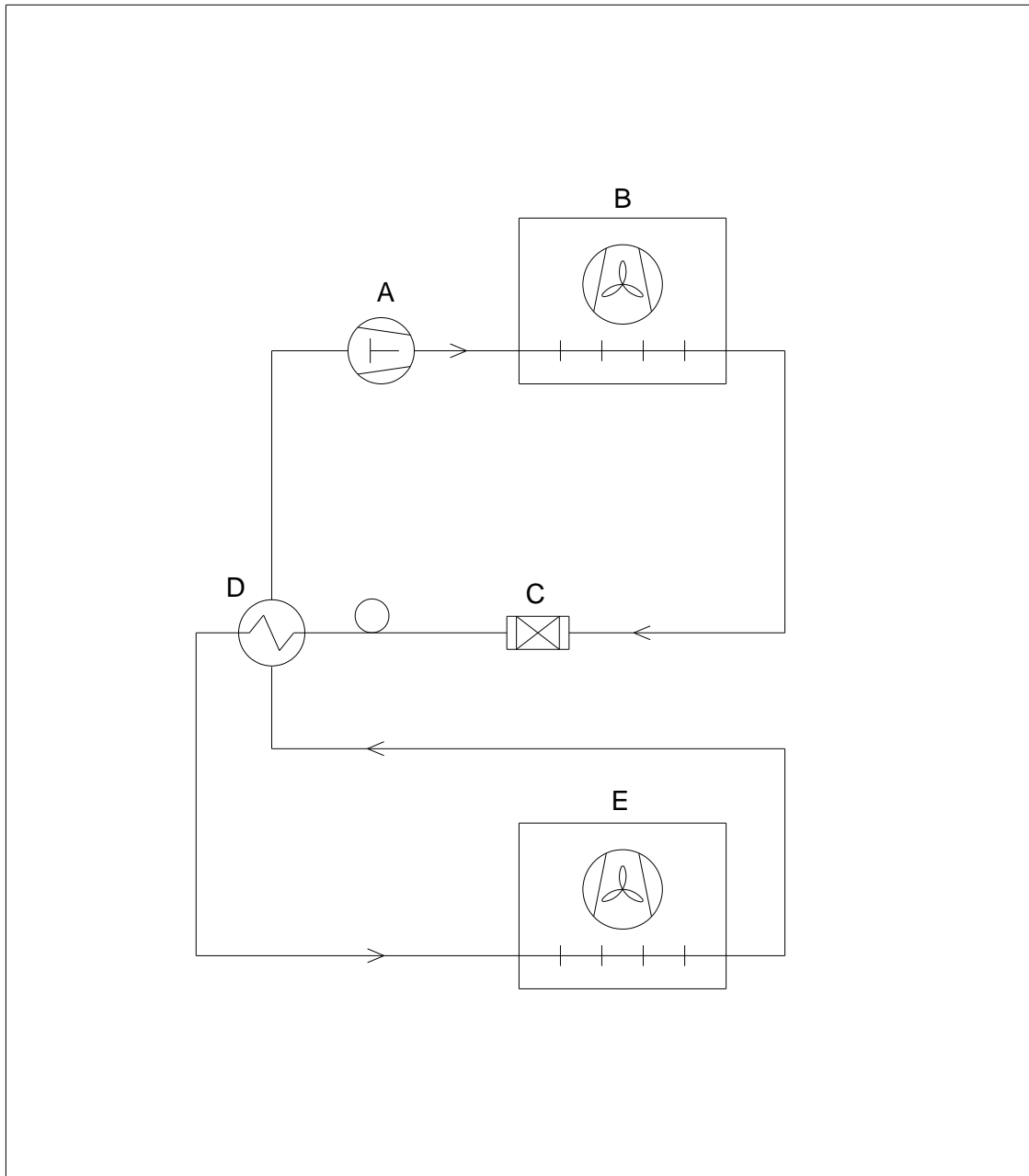

	DK	GB	D
A	Kompressor	Compressor	Kompressor
B	Kondensator	Condenser	Verflüssiger
C	Tørrefilter	Filter drier	Trockenfilter
D	Varmeudveksler	Heat exchanger	Wärmeaustauscher
E	Fordamper	Evaporator	Verdampfer